

Wabo®WaterTite

Plaza Deck/Split Slab Expansion Joint System

Features	Benefits
<ul style="list-style-type: none"> • Continuous sealing system 	Watertight expansion control system utilizes flashing sheet which integrates into hot applied deck waterproofing system.
<ul style="list-style-type: none"> • Multi-functional 	Accommodates pedestrian and vehicular traffic. Available in variable heights.
<ul style="list-style-type: none"> • Ease of installation 	Simple, easy to use connection between support angles and base members allow for quick installation.
<ul style="list-style-type: none"> • Ease of maintenance 	Removable stainless steel retainer cap allows for easy access to underlying components.

DESCRIPTION:

Wabo®WaterTite is a high performance, completely watertight expansion joint system. Wabo®WaterTite integrates the expansion joint into the waterproofing membrane in split slab applications through the use of a flashing sheet. The Wabo®WaterTite system combines a choice of versatile elastomeric seals for variable joint openings and system heights to accommodate split slab construction.

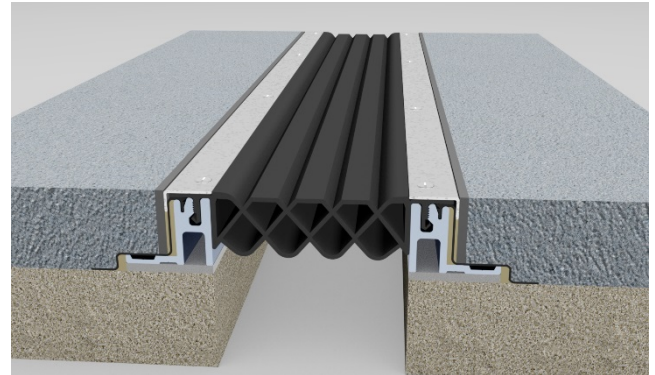

RECOMMENDED FOR:

- New construction or rehabilitation of parking structures, plaza decks, and split slab construction.
- Paver and concrete topped decks.
- Structures where water tightness is essential, such as areas over occupied spaces.

PACKAGING/COVERAGE:

- Aluminum Rail is shipped in 10 foot lengths on a pallet.
- Elastomeric Seal is shipped in continuous lengths.
- Hardware is packaged in cartons as required.

TECHNICAL DATA:

Design Information

The standard system is available with three different seal sizes; 2-inch, 4-inch, and 8-inch models. The standard systems can also accommodate variable heights from 1.5-inches to 4.5 inches. Custom designs are available, contact WBA for details.

Note: see product sales drawings for additional details

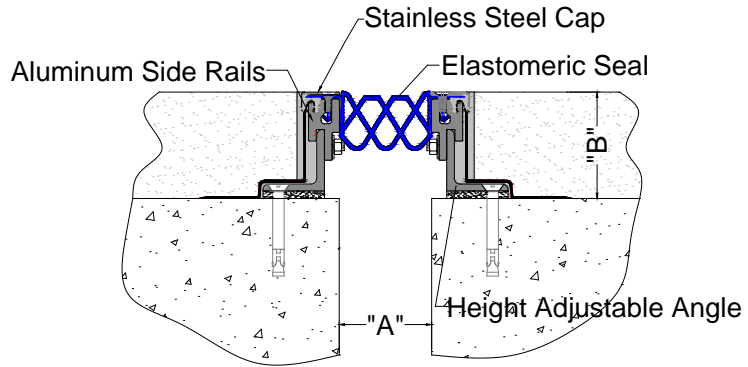

Model WT

Movement Table:

MODEL NUMBER	JOINT OPENING "A"						SYSTEM HEIGHT "B"	
	Min		Max		TOTAL		inches	mm
	inches	mm	inches	mm	inches	mm		
WT-200/150	0.75	19	3.0	76	2.25	57	1.5	38
WT-200/250	0.75	19	3.0	76	2.25	57	2.5	64
WT-200/350	0.75	19	3.0	76	2.25	57	3.5	89
WT-200/450	0.75	19	3.0	76	2.25	57	4.5	114
WT-400/150	1.50	38	5.0	127	3.50	89	1.5	38
WT-400/250	1.50	38	5.0	127	3.50	89	2.5	64
WT-400/350	1.50	38	5.0	127	3.50	89	3.5	89
WT-400/450	1.50	38	5.0	127	3.50	89	4.5	114
WT-800/150	2.50	64	12.0	305	9.50	241	1.5	38
WT-800/250	2.50	64	12.0	305	9.50	241	2.5	64
WT-800/350	2.50	64	12.0	305	9.50	241	3.5	89
WT-800/450	2.50	64	12.0	305	9.50	241	4.5	114

Note: Other system heights are available, contact WBA for details.

Physical Properties (Elastomeric Seal)

PHYSICAL PROPERTY	ASTM TEST METHOD	REQUIREMENTS
Tensile Strength, min	D-412	850 psi
Elongation at Break, min	D-412	300%
Hardness, Shore A	D-2240	67 +/- 3
100% Modulus, min	D-412	275 psi
Tear Strength, avg	D-624	140 lbs/in
Tension Set, avg	D-412	10%
Compression Set, max		
22 hrs @ 73°F	D-395	35%
70 hrs @ 257°F		45%
Ozone Resistance	D-1171	No cracks
UV Resistance	SAE J1960	Pass
Staining Resistance	D-925	No staining
Brittle Point	D-746	-81°F



We create chemistry

APPLICATION:

INSTALLATION SUMMARY:

- The joint opening must be abrasive blasted to remove all latencies and contaminants which may cause bonding problems. The joint opening should be blown clean using compressed air (>90psi).
- Structural concrete to be leveled using a high strength, high flow epoxy grout.
- Use anchoring devices and fasteners for securing expansion joint assembly in place.
- Perform all cutting and fitting required for installation of expansion joint system.
- Maintain continuity of expansion joint assembly and properly align all metal members.
- Integrate flashing sheet with deck waterproofing system materials. Install elastomeric seals in continuous lengths.
- WaboWaterTite must be installed per WBA Installation Procedure.

RELATED DOCUMENTS:

- Material Safety Data Sheets
- Wabo®WaterTite Specification
- Wabo®WaterTite Installation Procedure
- Wabo®WaterTite Sales Drawings

LIMITED WARRANTY:

Watson Bowman Acme Corp. warrants that this product conforms to its current applicable specifications. WATSON BOWMAN ACME CORP. MAKES NO OTHER WARRANTY, EXPRESS OR IMPLIED, INCLUDING ANY WARRANTY OF MERCHANTABILITY OR WARRANTY OF FITNESS FOR A PARTICULAR PURPOSE. The sole and exclusive remedy of Purchaser for any claim concerning this product, including, but not limited to, claims alleging breach of warranty, negligence, strict liability or otherwise, is the replacement of product or refund of the purchase price, at the sole option of Watson Bowman Acme Corp. Any claims concerning this product shall be submitted in writing within one year of the delivery date of this product to Purchaser and any claims not presented within that period are waived by Purchaser. IN NO EVENT SHALL WATSON BOWMAN ACME CORP. BE LIABLE FOR ANY SPECIAL, INCIDENTAL, CONSEQUENTIAL (INCLUDES LOSS OF PROFITS) OR PUNITIVE DAMAGES. Other warranties may be available when the product is installed by a factory trained installer. Contact your local Watson Bowman Acme representative for details. The data expressed herein is true and accurate to the best of our knowledge at the time published; it is, however, subject to change without notice.

FOR BEST RESULTS:

- Install when concrete substrate is clean, sound, dry, and cured (14 day minimum).
- Do not allow any of the components to freeze prior to installation. Store all components out of direct sunlight in a clean, dry location between 50°F and 90°F. Do not store in high humidity.
- Do not install if the joint's anticipated movement will exceed the system's movement range.
- Protect the work area with appropriate plastic sheeting.
- Minimize splice points by installing seals in longest possible continuous lengths.
- Periodically inspect the applied material and repair localized areas as needed. Consult a Watson Bowman Acme representative for additional information.
- Make certain the most current version of the product data sheet is being used. Please consult the website (www.wbacorp.com) or contact a customer service representative.
- Proper application is the responsibility of the user. Field visits by Watson Bowman Acme personnel are for the purpose of making technical recommendations only and not for supervising or providing quality control on the jobsite.



WaboWaterTite_0317

Watson Bowman Acme Corp.
95 Pineview Drive
Amherst, NY 14228
phone: 716-691-7566
fax: 716-691-9239
wbacorp.com

